

Podnośnik hydrauliczny słupkowy HSWH 5,0 t

Nr art.: WS1533





ciągnięcia,
przebiegów,
naczeł
maszyn,
pojazdów,

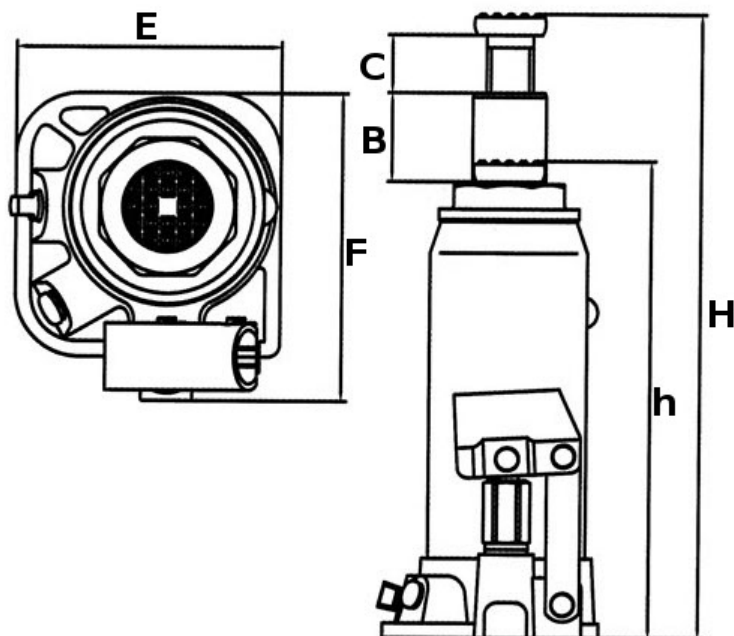

Dane techniczne

Model	Udźwig (t)	h [mm]	H [mm]	B [mm]	C [mm]	E [mm]	F [mm]	Waga [kg]
HSWH 5	5,0	216	413	127	70	96	112	4,5